

B METERS

Nedvesen futó vízmennyiségmérő

típ. **GMB-RP**
wet-dial

classe C



iso 9001:2000
cert. n. 1798



cee 75/33
iso 4064



Típus: GMP

Metrológiai
osztály: C

Stabilis

Kiemelkedő mérési
eredmények és tartós

Stabilis

Gyártott méretek:

Technikai adatok - Technical features

Méreték Size		mm	13	20
		in	(1/2")	(3/4")
Maximális térfogatáram Capacity (with 10 m of loss of head)	Q_{max}	m ³ /h	3	5
Névleges térfogatáram Nominal flow	Q_n	m ³ /h	1,5	2,5
Átmeneti térfogatáram Accuracy limits	$\pm 2\% Q_t$	l/h	120	200
	$\pm 5\% Q_{min}$	l/h	30	50
Leolvashatóság Reading dial	min	l	0,05	0,05
	max	m ³	10.000	10.000
				100.000
Maximális nyomás Max working pressure		bar	16	16

Mérési osztály C-H
Class C-H

Hideg vízre 30°C
Cold water 30°C

Mechanikus hajtás
Mechanical transmission

Görgős számláló
Immediate reading

Öt számgörgő
Wet dial

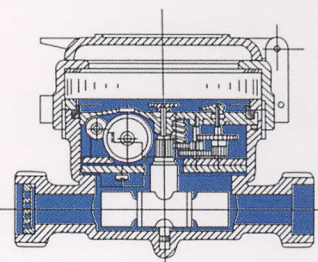

Méreték ábrázolása - Dimensions and weights

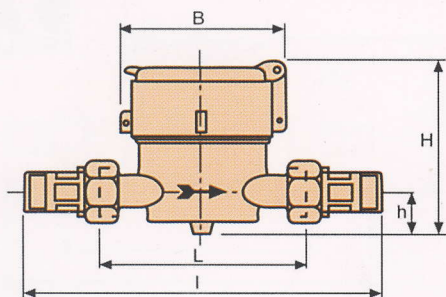

Méreték	mm	13	20	
Size	in	1/2"	3/4"	
L	mm	110 (145)	130	
l	mm	190 (225)	228	
H	mm	83	83	
h	mm	18	18	
B	mm	85	85	
Súly	Csatlakozóval with unions	Kg	0,83 (0,90)	1,01
Weights	Csatlakozó nélkül without unions	Kg	0,69 (0,75)	0,80

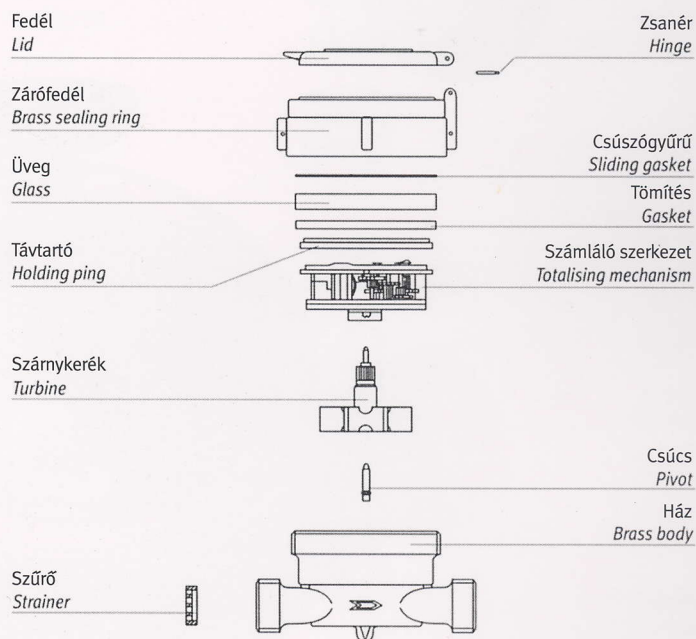

Mérési hibagörbe Typical error curve of turbine meters

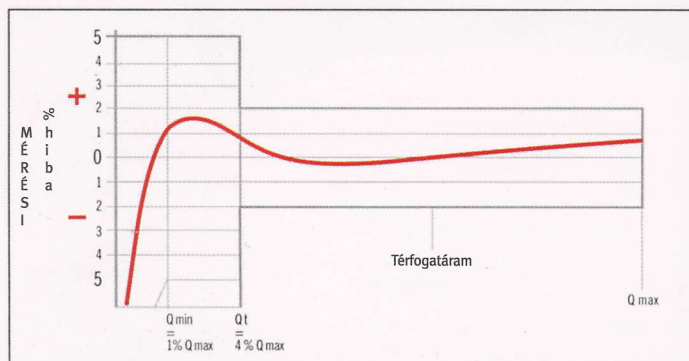

Nyomásvesztési diagram Loss of head curve of ϕ 13 and 20 mm. water meters

